

CHARACTERISTICS

Deep Cycle Series

| | | |
|--|---------------------|-----------------------|
| Nominal voltage | | 12V (6 cell per unit) |
| Nominal capacity at 10 hours rate/10.8V (25°C) | | 78Ah |
| Capacity (25°C) | 20 Hours rate/10.8V | 82.6Ah |
| | 5 Hours rate/10.8V | 66.5Ah |
| Terminal type | | M6 |
| Torque | | 5.1±0.6 N.m |
| Approx. internal resistance (25°C) | | 5.5 mΩ |
| Dimensions | Length | 260±2mm |
| | Width | 168±2mm |
| | Height | 211±2mm |
| | Total height | 215±2mm |
| Design Life (stand-by) | JIS at 25°C | 10 years |
| | Eurobat at 20°C | 10/12 years |
| Weight | | 24.50kg ±3% |
| Nominal operating temperature | | 25±3°C |
| Operating temperature range | Discharge | -15°C~50°C |
| | Charge | -10°C~50°C |
| | Storage | -20°C~50°C |
| Float charging voltage at 25°C | | 13.5V~13.8V |
| Cyclic charging voltage at 25°C | | 14.5V~15.0V |
| Temperature compensation | Float charge | -18 mV/°C/Block |
| | Cycle charge | -30 mV/°C/Block |
| Max. charging current (A) | | 22.5A |
| Max. discharge current for 5 seconds | | 700A |
| Self discharge rate (25°C) | | ≤3%/month |
| Battery container ABS UL94-HB | | V-0 optional |

DIMENSIONS & TERMINAL TYPE (MM)

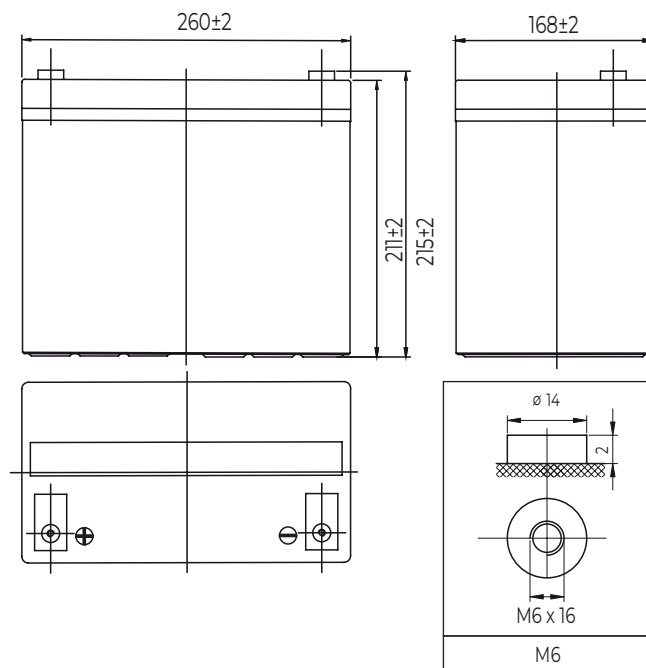

CERTIFICATION & COMPLIANCES



Compliant to: EUROBAT, RoHS, WEEE's and Reach.
Manufactured according to IEC 60896-21 / 22

CONSTRUCTION

| Component | Positive Plate | Negative plate | Container | Separator | Electrolyte | Safety valve | Terminal |
|--------------|----------------|----------------|----------------|-----------|---------------|--------------|----------|
| Raw material | Lead dioxide | Lead | ABS (V-0 opt.) | AGM | Sulfuric Acid | Rubber | Copper |

CONSTANT CURRENT DISCHARGE CHARACTERISTICS AT 25°C

(Ampere/battery)

| F.V/Time | 10min | 15min | 30min | 60min | 2hr | 3hr | 4hr | 5hr | 8hr | 10hr | 20hr |
|----------|-------|-------|-------|-------|------|------|------|------|------|------|------|
| 9.60V | 170 | 131 | 78.4 | 48.2 | 28.5 | 20.5 | 16.4 | 14.0 | 9.63 | 7.94 | 4.21 |
| 9.90V | 165 | 128 | 76.8 | 47.5 | 28.3 | 20.4 | 16.3 | 13.9 | 9.57 | 7.92 | 4.20 |
| 10.2V | 158 | 123 | 74.5 | 46.3 | 28.1 | 20.3 | 16.2 | 13.8 | 9.50 | 7.90 | 4.19 |
| 10.5V | 151 | 119 | 72.7 | 44.8 | 27.7 | 20.1 | 16.1 | 13.7 | 9.44 | 7.85 | 4.16 |
| 10.8V | 143 | 113 | 70.0 | 43.4 | 27.0 | 19.5 | 15.6 | 13.3 | 9.15 | 7.80 | 4.13 |

CONSTANT POWER DISCHARGE CHARACTERISTICS AT 25°C

(Watts/battery)

| F.V/Time | 10min | 15min | 30min | 60min | 2hr | 3hr | 4hr | 5hr | 8hr | 10hr | 20hr |
|----------|-------|-------|-------|-------|-----|-----|-----|-----|-----|------|------|
| 9.60V | 1836 | 1439 | 880 | 550 | 330 | 241 | 193 | 166 | 114 | 94.8 | 50.5 |
| 9.90V | 1781 | 1404 | 862 | 541 | 328 | 240 | 192 | 165 | 114 | 94.6 | 50.4 |
| 10.2V | 1708 | 1352 | 836 | 528 | 325 | 238 | 190 | 163 | 113 | 84.3 | 50.3 |
| 10.5V | 1634 | 1306 | 815 | 511 | 320 | 237 | 189 | 162 | 112 | 93.8 | 50.0 |
| 10.8V | 1543 | 1237 | 785 | 495 | 312 | 230 | 183 | 157 | 109 | 93.1 | 49.6 |

The above characteristics represent average values and can be obtained within three charge and discharge cycles. The batteries must be fully charged before testing. The data in this document is subject to change without notice and become contractual only after written confirmation. Please contact Avacom for the latest available version.